

Certified processes. First-class quality.

High quality is a hallmark of ZOLLERN products. In addition to stringent quality assurance of the individual products, ZOLLERN's management system is also certified according to the international standards ISO 9001 and IATF 16949. ISO 14001 and ISO 50001-certified environmental and energy management systems are also a living part of our daily practice.

- At ZOLLERN, error prevention has priority over error correction. The aim is to achieve a zero error rate, meaning that customer requirements are fully satisfied.
- ZOLLERN's operations are accompanied by continuous improvements to our processes, our organisational structure and ultimately our products and services. In addition to ongoing improvements in the relevant areas, the employee suggestion scheme also makes a major contribution in this respect.
- Employee orientation, training and development and optimal working conditions are important elements of ZOLLERN's corporate policy. In this way, we aim to achieve excellence both today and in the future in national and international markets, whilst at the same time conserving resources and protecting the environment.

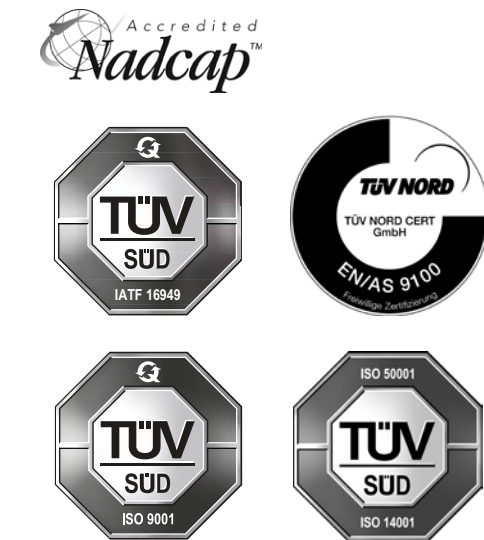

Quality assurance and material testing

ZOLLERN uses a wide range of methods and instruments to ensure product quality. Material tests are certified according to DIN EN 10204 and conducted throughout the entire manufacturing process.

Testing of mechanical and technological properties

- Tensile testing machines
- Hardness testers for all standards
- Fully automatic low-load hardness testers
- Notched-bar impact testing

Metallographic testing

- Laboratory for sample preparation, e.g. hot mounting and specimen preparation
- Various microscopes and microscopes allow precise material analysis

Determination of chemical composition

- Spectral analysis
- Chemical analysis

Geometry and surface roughness tests

- Measuring machines – optical, tactile and digital
- Roughness measuring devices

Linearity and torsion tests

- Measuring tables, measuring bridges of various lengths and angle measuring devices

Refinement of heat treatments, determination of tempering temperatures

- Laboratory furnaces

Non-destructive test procedures

- Crack detection tests based on the eddy current and magnetic powder principles
- Ultrasonic tests
- Positive material identification

ZOLLERN

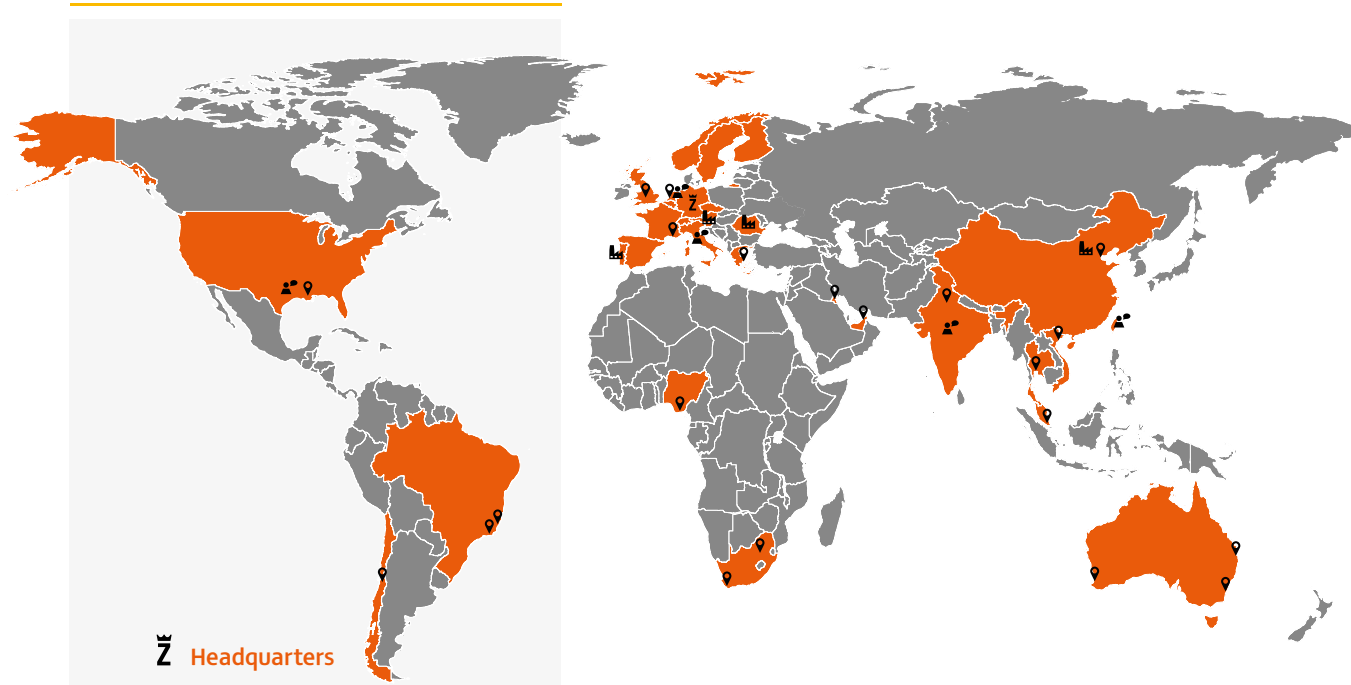

Headquarters

Subsidiaries

Italy and southern Europe
Netherlands and Northern Europe
USA
India and Southeast Asia
Taiwan, China

Factories

Germany
Portugal
Romania
Slovenia
China

Service partner

Australia
Brazil
Chile
Greece
Great Britain
Kuwait
Singapore
South Africa
Thailand
Dubai
USA
Vietnam



ZOLLERN-worldwide



ZOLLERN-Products

ZOLLERN GmbH & Co. KG

Hitzkofer Strasse 1
72517 Sigmaringendorf-Lauchertal
Germany
T +49 7571 70-0
F +49 7571 70-602
info@zollern.com
www.zollern.com



ZOLLERN

Solid metals. Fine solutions.

Investment Casting
Sandcasting and Forging
Gas Turbines
Aero-Derivatives

Photography: Getty Images; photographer: Stewart Sutton – iStock; photographer: superjoseph – Siemens AG © ZOLLERN | 04_24 | 113 | www.creativ-webbing.com Errors and amendments excepted. Pictures and illustrations similar.



The ZOLLERN-Group
 With first-class products and customized solutions in the sectors drive technology, investment casting, sand casting and forging as well as steel profiles we are one of the leading manufacturers – worldwide.

As one of the oldest family-run businesses in Germany we are proud to look back on an impressive 300-year history during which we have merged tradition with innovation. Our main focus is on excellent quality and service.

Welcome to the world of ZOLLERN, where experience and progress go hand in hand to offer our customers the best solutions and products for their requirements in various industrial sectors.

Sophisticated components for industrial gas turbines, steam turbines and aero-derivatives



ZOLLERN – Investment Casting produces extremely hard-wearing precision investment casting products with almost limitless design possibilities in Laucherthal, Germany, as well as at other company sites in Soest, Slovenia, Romania and Portugal. ZOLLERN products include high-performance turbine blades for gas turbines, for example. Our in-house manufacturing capacity ranges from the master melt through to ready-to-install investment casting parts including all finishing. The experienced specialists at ZOLLERN cast virtually all standardised alloys. We are also able to produce non-standardised special alloys to customer specifications.



ZOLLERN – Sandcasting and Forging was founded in 1708. This is the oldest business unit within the ZOLLERN group. At our factory in Laucherthal, Germany, we manufacture components in copper, copper alloy and high and low alloy steel using sand casting, ceramic casting and centrifugal casting. Our components are characterised by quality materials, precision processing and outstanding surface properties; they are cast from a selection of over 500 alloys and are used in the energy generation industry amongst others.

Industrial Gas Turbines

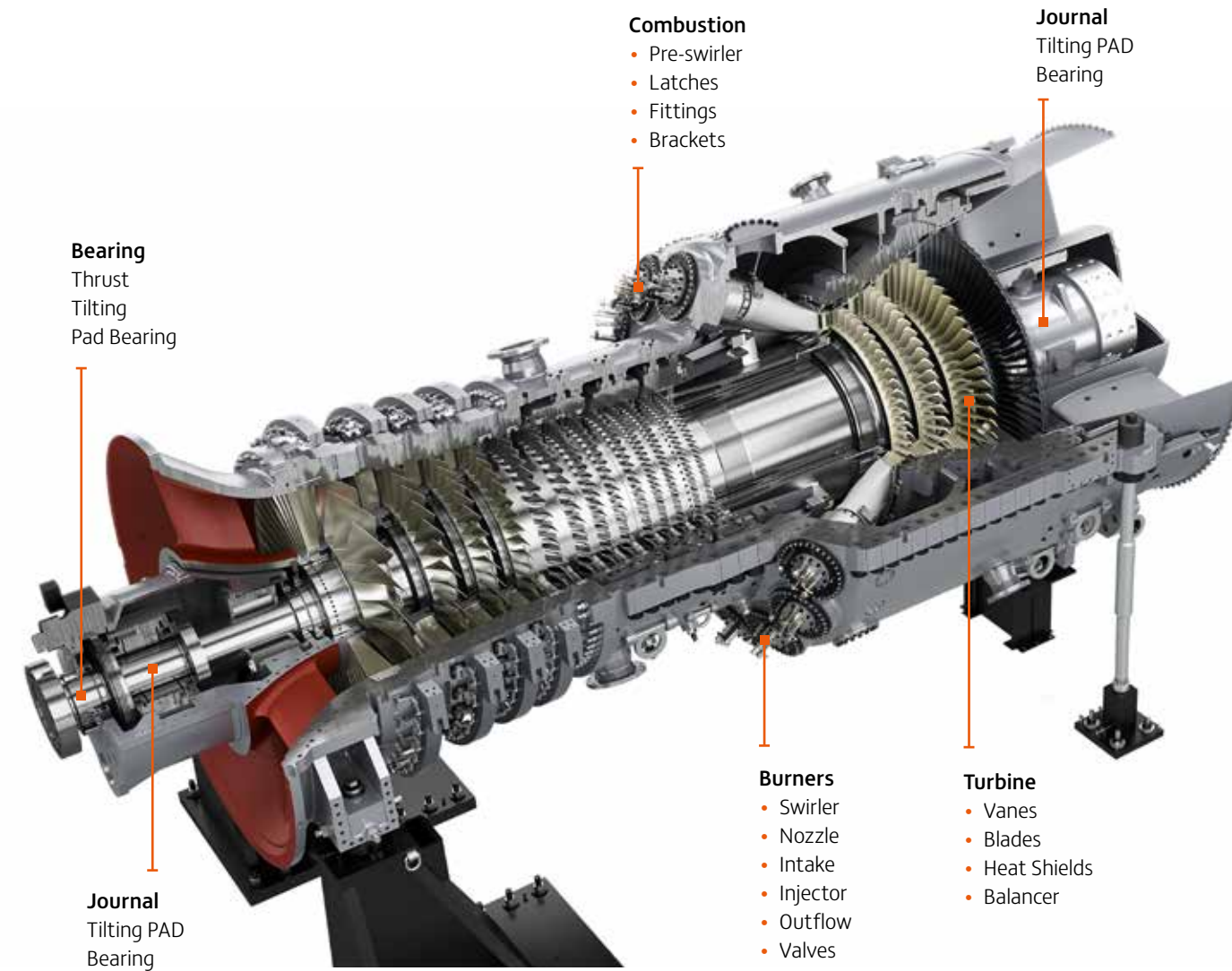

Product Samples IGT GT 8000H

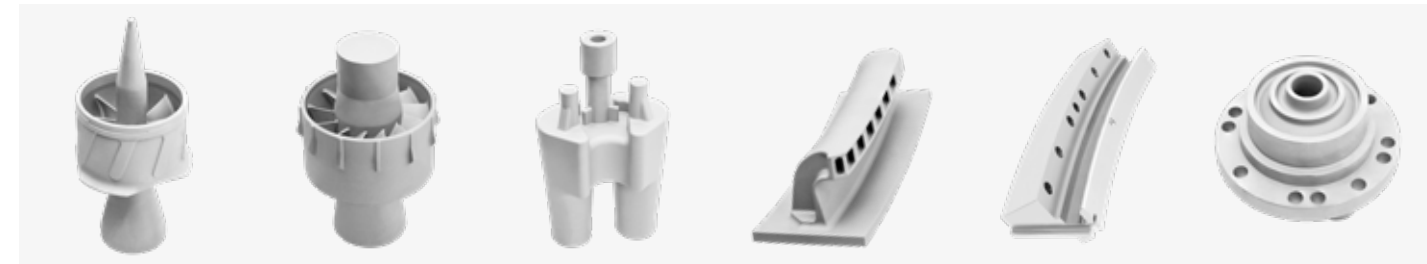

Product Samples div.



Aero-derivatives/Engines

